

NC 115 SF

Architectural Envelope Storefront System

Manufactured and Distributed by:



40 Murphy Drive, Avon, MA 02322

Tel: 508-588-4845 • 800-498-4845

Fax: 508-587-3939

www.archglazing.com

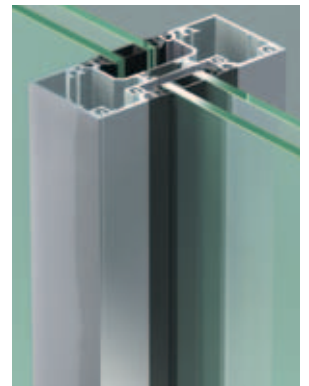

NC 115 SF



Features

- 6063 T5 Aluminum Alloy Frame
- Shop or On-Site Glazing
- Frame Depth 114 mm [4.5"]
- Captured Glazing
- Various Glass Size
- Weather Stripping: EPDM Gaskets
- Thermal Barrier: Polyamide
- Straight cut 90° with Fasteners
- Custom Color
- Painted or Anodizing Finish
- Dual Finish Available
- Durable Components

Benefits

- Simple Installation
- Acoustic Insulation
- Thermal Insulation
- Inswing Outswing Door Solution Available
- Easy Maintenance
- Easy Glass Replacement

Applications

- Storefronts
- Low-Rise Buildings

Technology

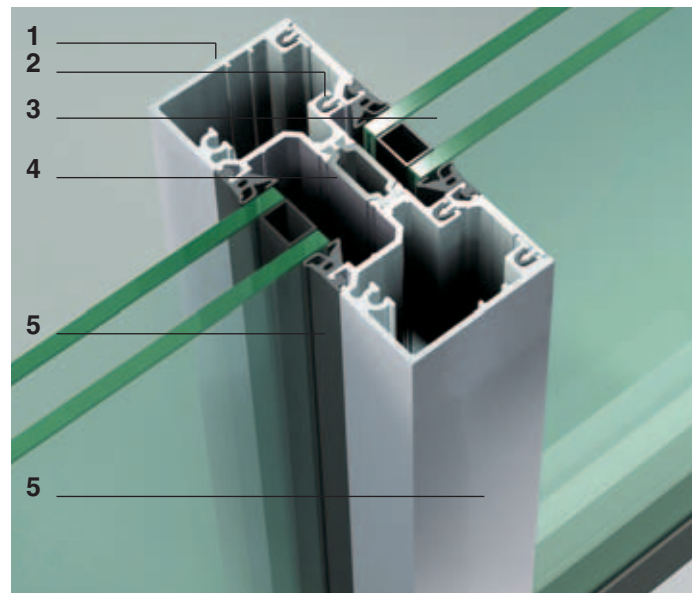

1. Mullion
2. Cover
3. Insulating Glass Unit
4. Polyamidic Thermal Barrier
5. EPDM Gaskets
6. Painted or Anodized Finish

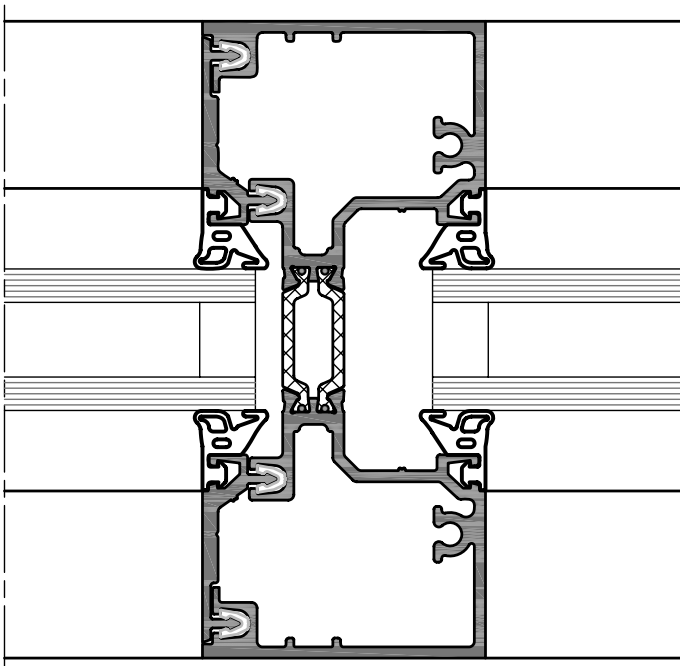

Horizontal section

Opening Solutions



Single door opening outward Single door opening inward Double door opening outward Double door opening inward

Thermally Insulated, Single and Double, Opening Inward and Outward Store Entrance Doors.

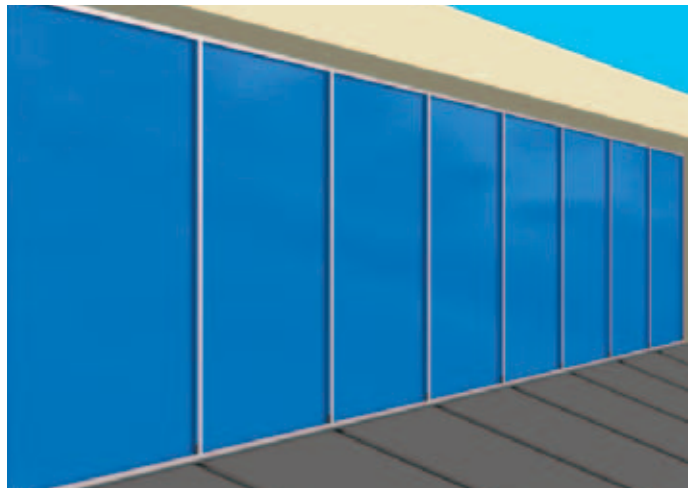
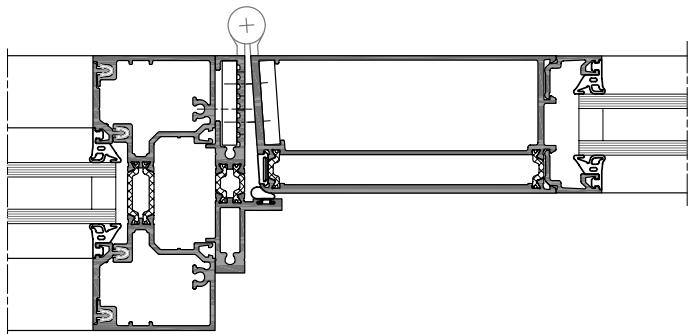

Quality

METRA stands for quality and optimal performance. Only original METRA profiles and accessories can certify the highest performance. Original METRA products have an "M" mark on the interior surface.

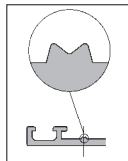

METRA quality is certified by ISO 9001. METRA controls the entire process of production for the extrusions. Manufacturing and installation of final products are performed through a network of independent specialists.



Manufactured and Distributed by:



40 Murphy Drive, Avon, MA 02322
Tel: 508-588-4845 • 800-498-4845
Fax: 508-587-3939
www.archglazing.com



METRA
SYSTEMS

METRA Systems
1995 Industrial Blvd. - Laval, QC H7S 1P6, Canada
Tel. +1 450 629 4260 - Fax +1 450 629 7313
info@metrasystem.com
www.metrasystem.com



METRA

METRA S.p.A.
Via Stacca, 1 - 25050 Rodengo Saiano (BS) Italy
Tel. +39 030 6819.1 - Fax +39 030 6819 990
metra@metra.it
www.metra.eu

METRA prints on ecologically friendly paper
and uses printing products with low
environmental impact.



METRA Products

Architectural Envelope

Entrances & Windows

Special Systems

Sliding Systems

Accessories

Printed in September 2009